

- BG** Инструкции за инсталиране  
**Внимание!** Преди да пристъпите към инсталирането, прочетете информацията за безопасност в Ръководството за потребителя.
- CS** Pokyny k instalaci  
**Upozornění!** Před začátkem instalace si přečtěte bezpečnostní informace v návodu k použití.
- DA** Installationsvejledning  
**Vigtigt!** Læs brugsanvisningens instruktioner vedrørende sikkerhed, før installationen påbegyndes.
- DE** Montageanweisung  
**Achtung!** Lesen Sie vor Beginn der Installation die Sicherheitshinweise in der Gebrauchsanweisung.
- EL** Οδηγίες εγκατάστασης  
**Προειδοποίηση!** Πριν συνεχίσετε με την εγκατάσταση, διαβάστε τις πληροφορίες ασφαλείας στο εγχειρίδιο χρήστη.
- EN** Installation Instruction  
**Warning!** Before proceeding with installation, read the safety information in the User Manual.
- ES** Instrucciones de instalación  
**¡Atención!** Antes de realizar la instalación, lea la información de seguridad del Manual del usuario.
- ET** Paigaldusjuhvis  
**Hoiatus!** Enne paigaldamist lugege läbi kasutusjuhendis olevad ohutusjuhised.
- FI** Asennusohjeet  
**Varoitukset!** Ennen kuin aloitat asennuksen, lue käyttöohjeen sisältämät turvallisuusohjeet.
- FR** Instructions d'installation  
**Attention!** Veuillez lire les consignes de sécurité que contient la Notice d'utilisation avant d'installer l'appareil.
- HR** Upute za instalaciju  
**Upozorenje!** Prije instalacije pročitajte sigurnosne informacije u Uputama za uporabu.
- HU** Üzembe helyezési útmutató  
**Vigyázat!** Mielőtt továbblépne az üzembe helyezésessel, olvassa el a biztonsági információkat a felhasználói kézikönyvben.
- IT** Istruzioni di installazione  
**Attenzione!** Prima di procedere all'installazione, leggere le istruzioni di sicurezza contenute nel Libretto Istruzioni.
- LT** Įrengimo instrukcija  
**Įspėjimas!** Prieš montuodami perskaitykite saugos informaciją naudojimo instrukcijoje.
- LV** Uzstādīšanas norādījumi  
**Brīdinājums!** Pirms turpināt uzstādīšanu, izlasiet lietotāja rokasgrāmatā ietvertu drošības informāciju.

- NL** Installatie-instructies  
**Waarschuwing!** Lees de veiligheidsinformatie in de gebruikershandleiding voordat u met de installatie begint.
- NO** Monteringsanvisning  
**Advarsel!** Les sikkerhetsinformasjonene i bruksanvisningen før du begynner installasjonen.
- PL** Wskazówki dotyczące instalacji  
**Ostrzeżenie!** Przed rozpoczęciem instalacji należy przeczytać informacje dotyczące bezpieczeństwa podane w Instrukcji obsługi.
- PT** Instruções de instalação  
**Atenção!** Antes de continuar a instalação, leia as informações de segurança no Manual de Utilizador.
- RO** Instrucțiuni de instalare  
**Atenție!** Înainte de a trece la instalare, citiți informațiile privind siguranța din Manualul Utilizatorului.
- RU** Указания по установке  
**Внимание!** Перед тем как приступить к установке, прочтите информацию по технике безопасности в руководстве пользователя.
- SK** Pokyny na inštaláciu  
**Upozornenie!** Pred inštaláciou si prečítajte bezpečnostné pokyny v návode na používanie.
- SL** Navodila za namestitvev  
**Opozorilo!** Pred nadaljevanjem z namestitvijo preberite varnostna navodila v navodilih za uporabo.
- SQ** Udhëzime Instalimi  
**Paralajmërim!** Përpara se të kryeni instalimin, lexoni të dhënat e sigurisë në Manualin e Përdorimit.
- SR** Упутство за инсталирање  
**Упозорење!** Пре него што приступите инсталирању уређаја, прочитајте информације о безбедности у Упутству за употребу.
- SV** Installationsanvisningar  
**Varning!** Läs säkerhetsanvisningarna i bruksanvisningen innan du fortsätter med installationen.
- TR** **UK** 



**TR**

**Montaj Talimatları**

**Uyarı!** Montaj işlemine başlamadan önce, kullanma kılavuzundaki güvenlik bilgilerini okuyunuz.

**UK**

**Інструкція з установки**

**Увага!** Перед початком встановлення прочитайте інформацію щодо безпеки у Посібнику користувача.



**YouTube**

[www.youtube.com/electrolux](http://www.youtube.com/electrolux)  
[www.youtube.com/aeg](http://www.youtube.com/aeg)



**YouTube**

[www.youtube.com/electrolux](http://www.youtube.com/electrolux)  
[www.youtube.com/aeg](http://www.youtube.com/aeg)

How to install your Electrolux induction extractor hob



How to install your AEG induction extractor hob

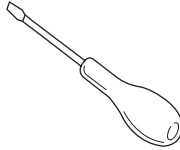
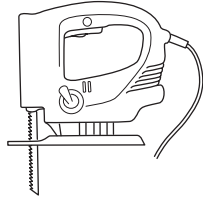

1

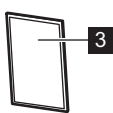

3

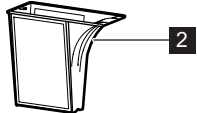

2

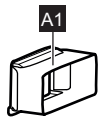

A1



A2

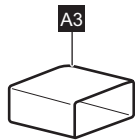

A3

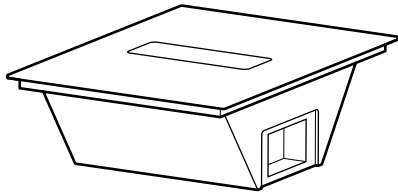

A4



A5

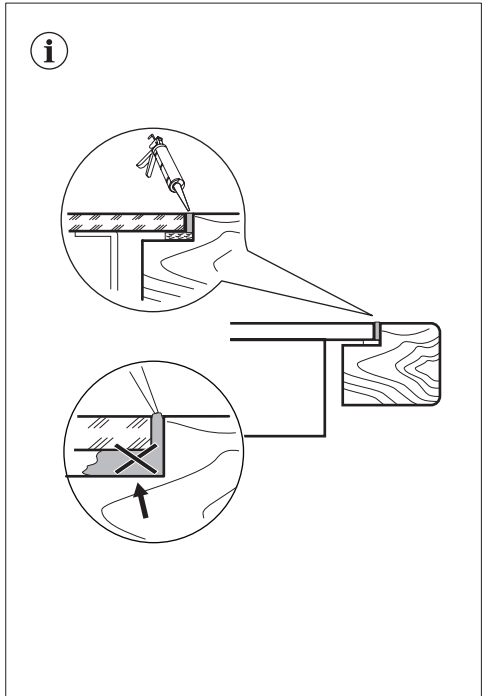
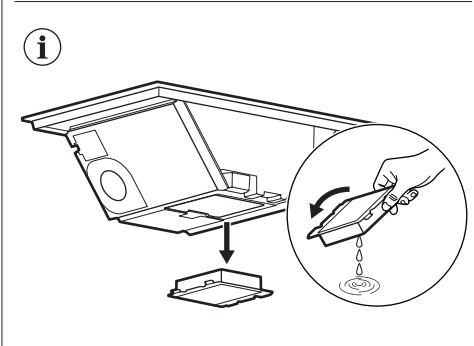
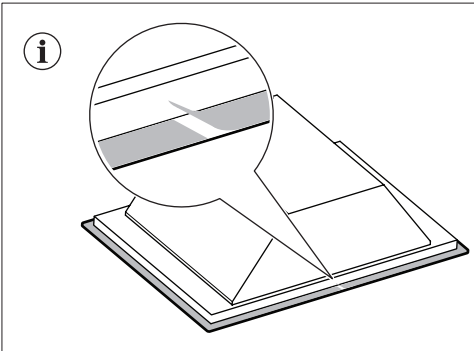
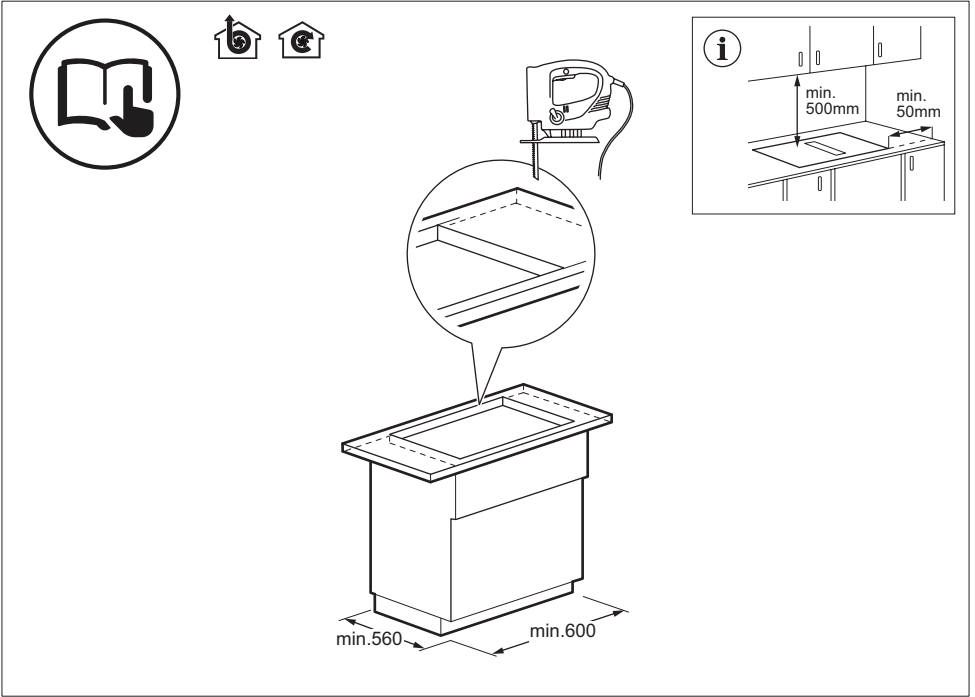



**A**

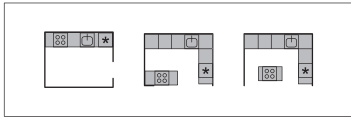
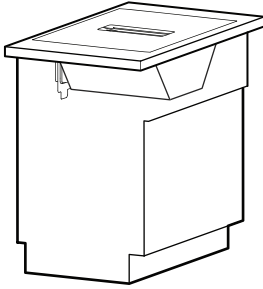

**B**

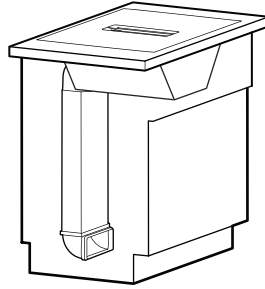

**C**

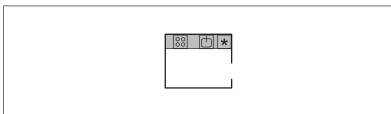
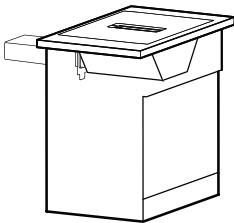

**D**

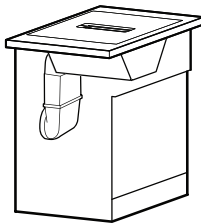

**E**

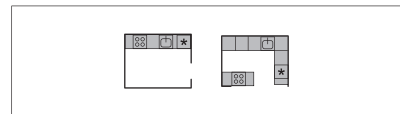
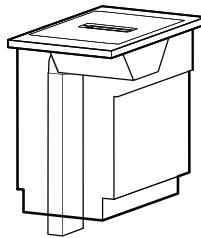

**F**

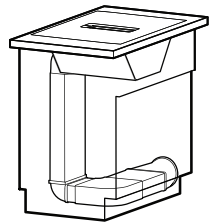



**A**

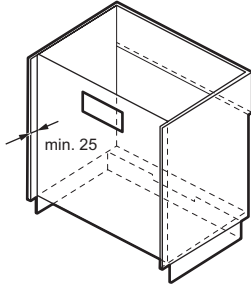

**B**

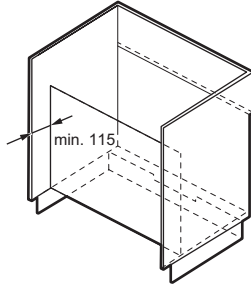

**C D E F**

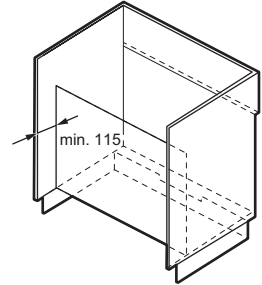

**B C D E F**

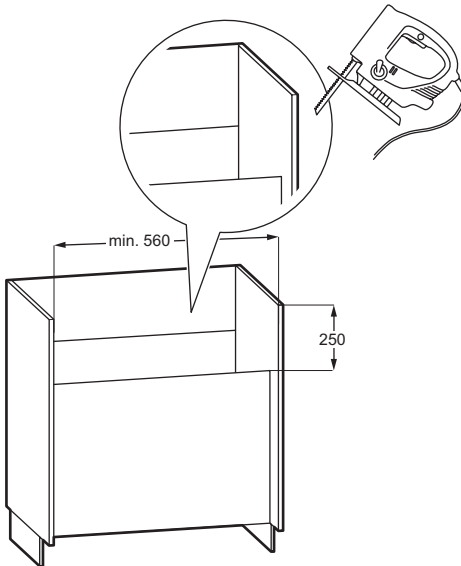

**i**

**B C D**

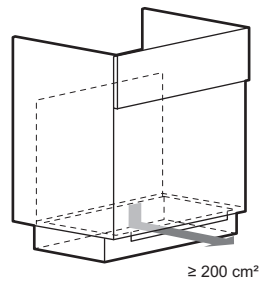
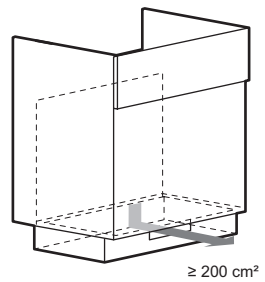



**A**

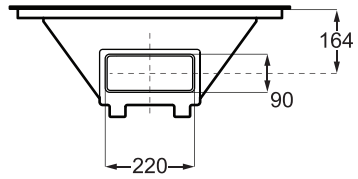
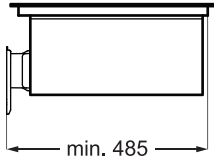
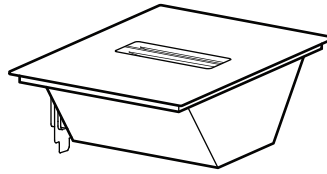
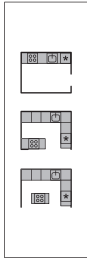

**1. A.**

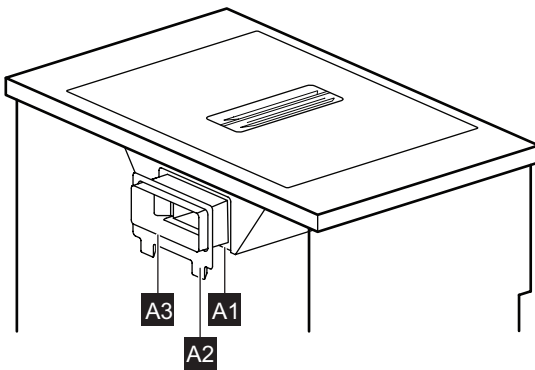
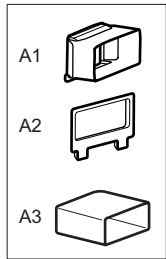

# 2. A.

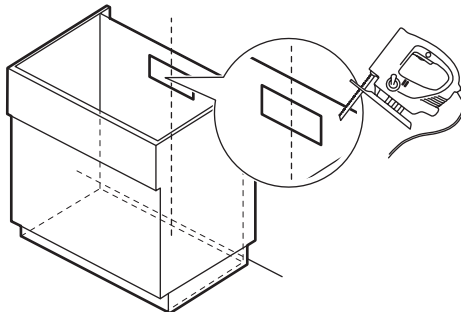
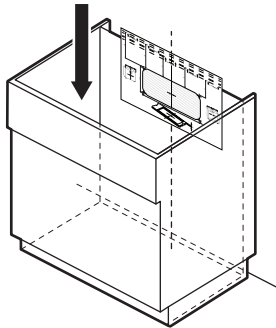
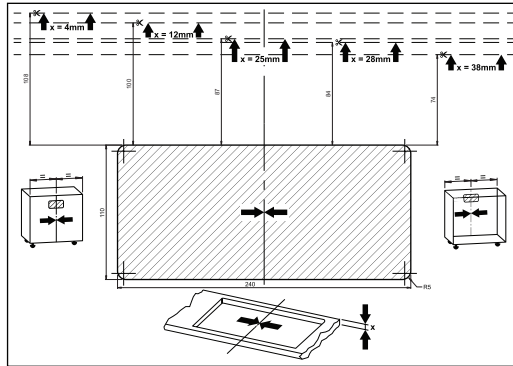

### 3. A.

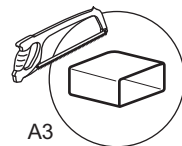
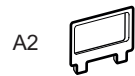
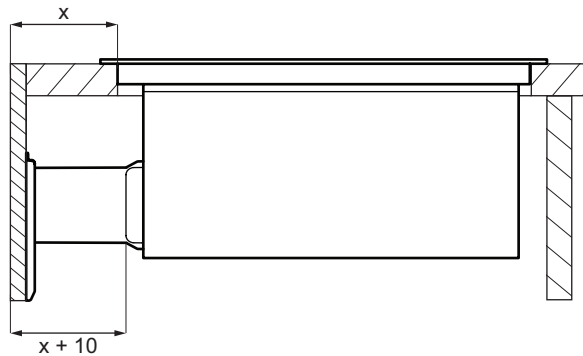
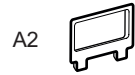
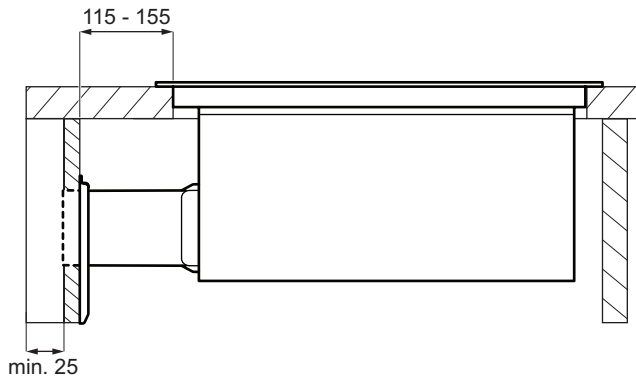
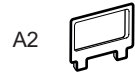
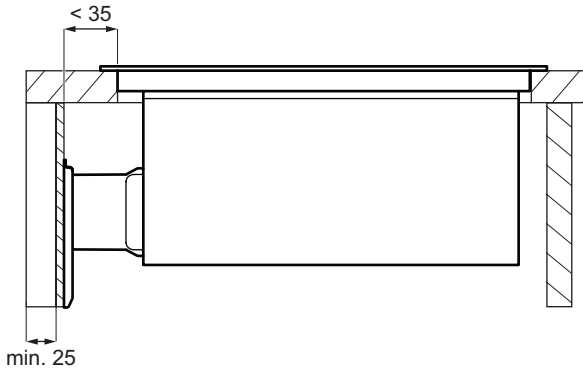

# 4. A.

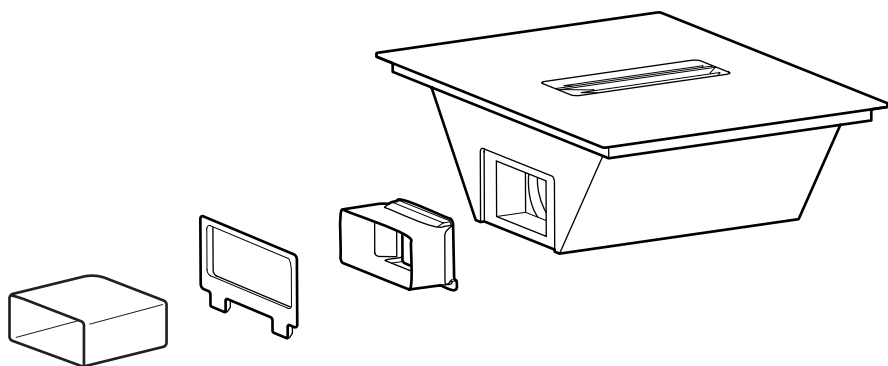

# 5. A.

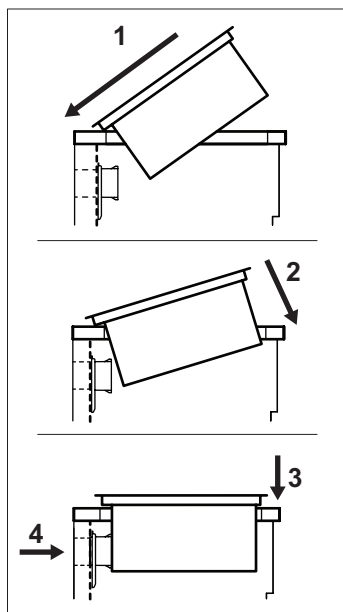
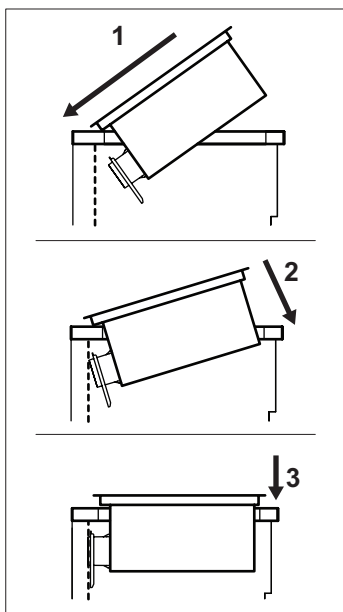

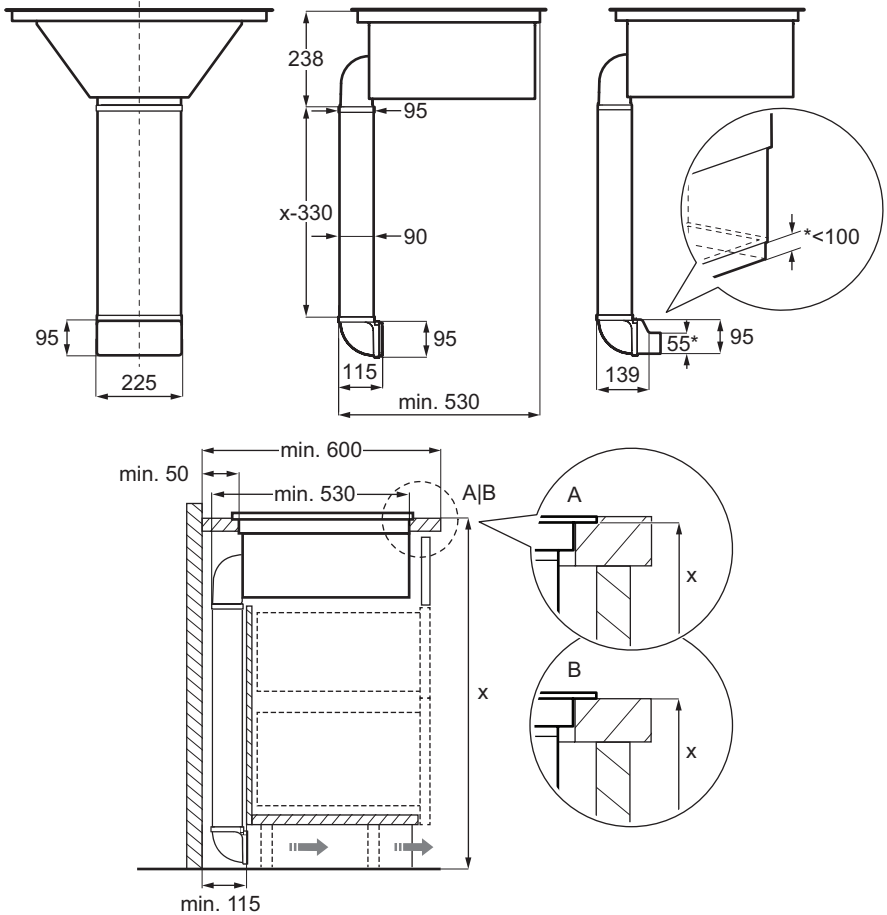
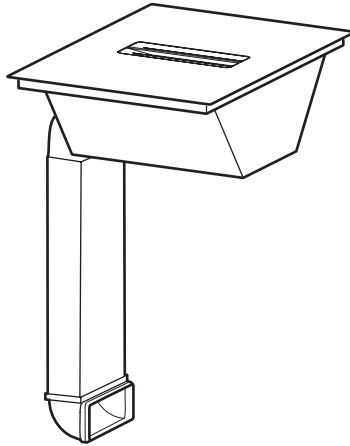
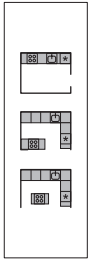
**B**

**B**



A4



K1

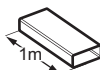

K2



A4

K1

K2

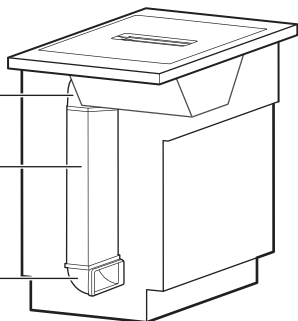

**1. B.**

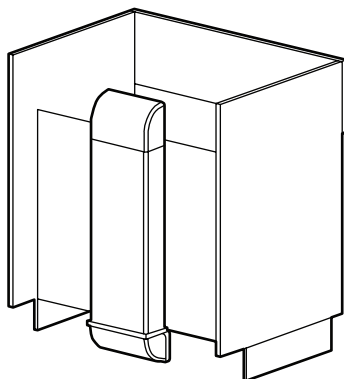
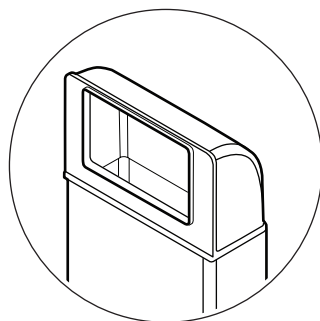

# 2. B.

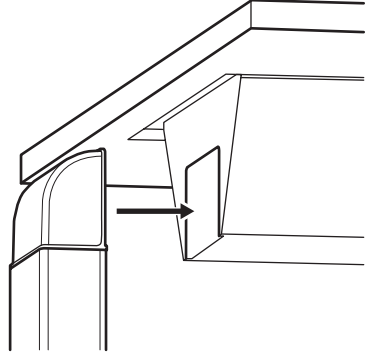
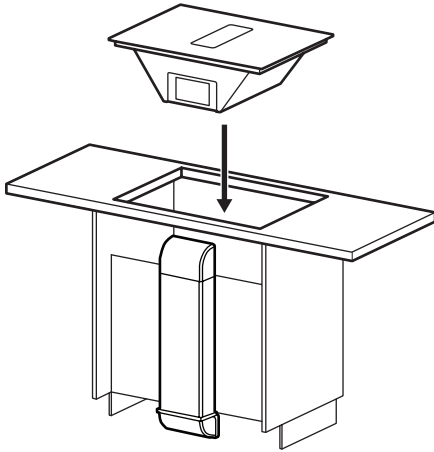

**C**

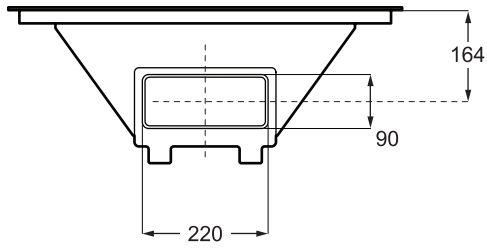
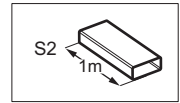
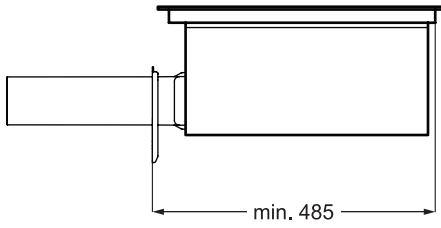
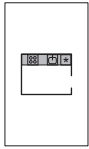

**1. C.**

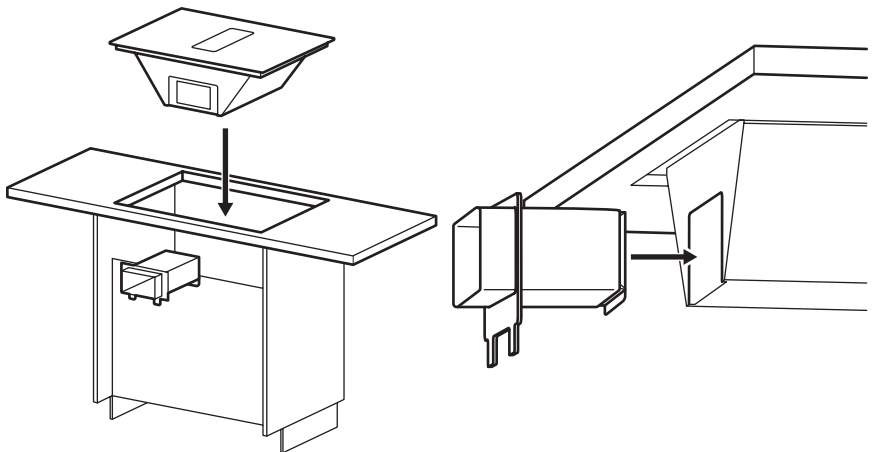

**D**

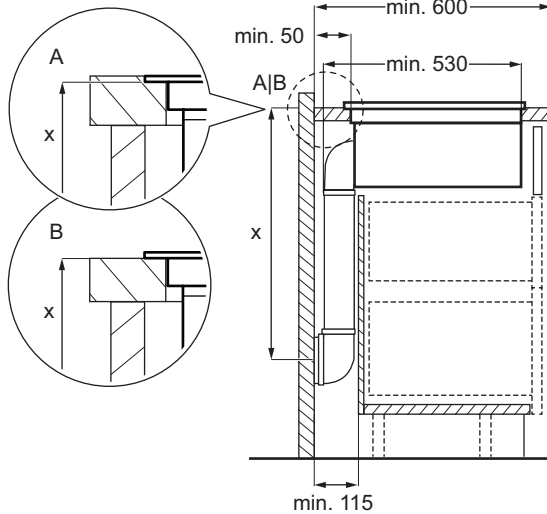
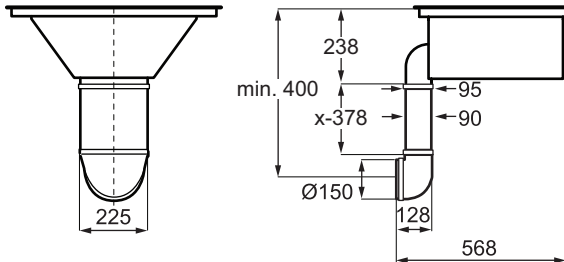
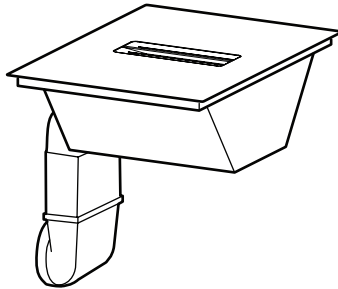
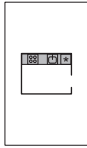

# 1. D.

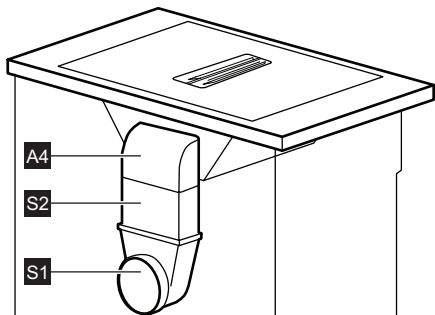
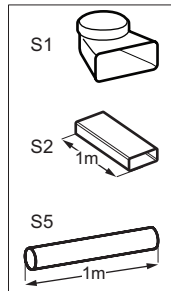

# 2. D.

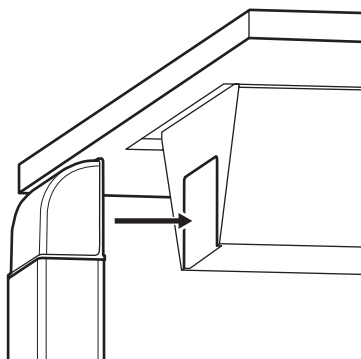
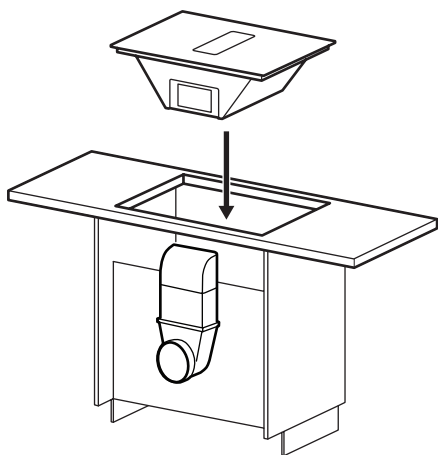

**E**

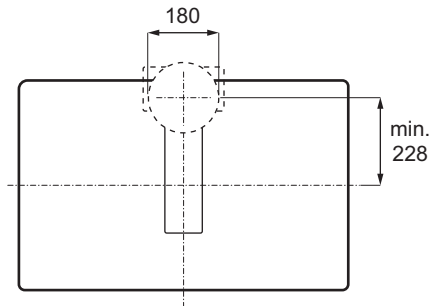
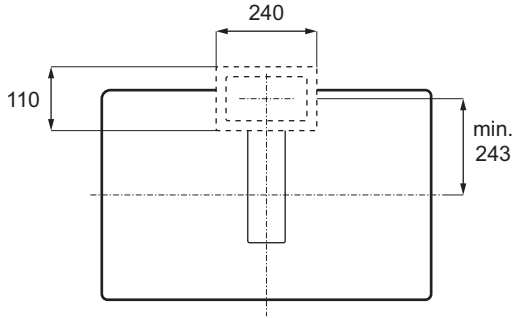
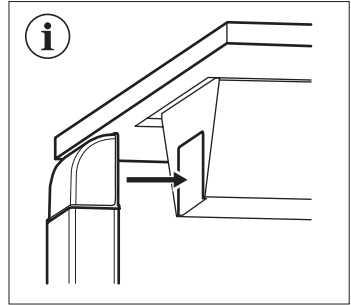
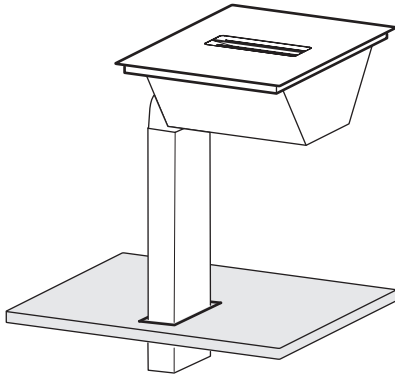
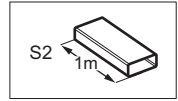

**F**

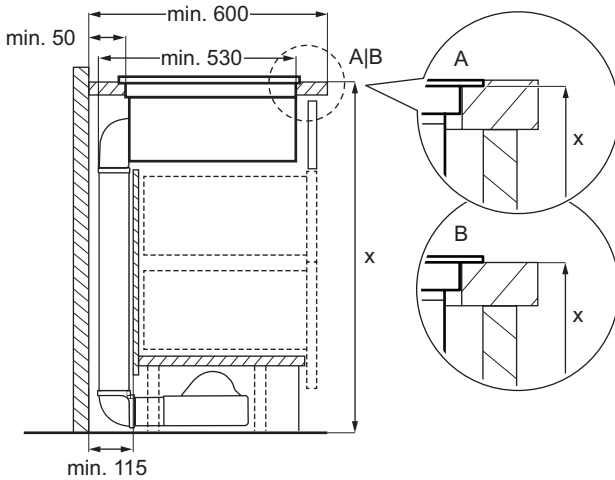
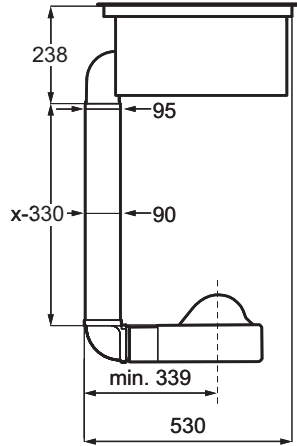
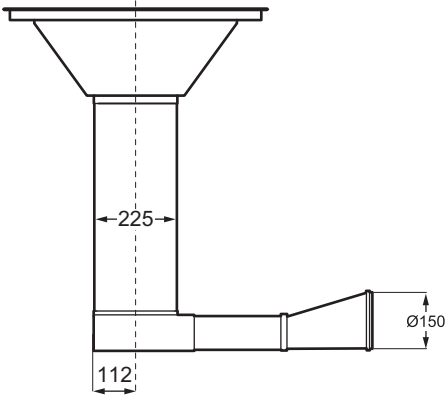
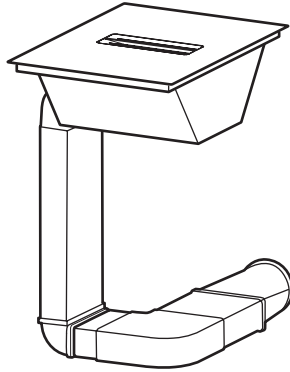
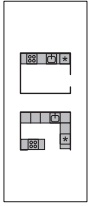

# 1. F.

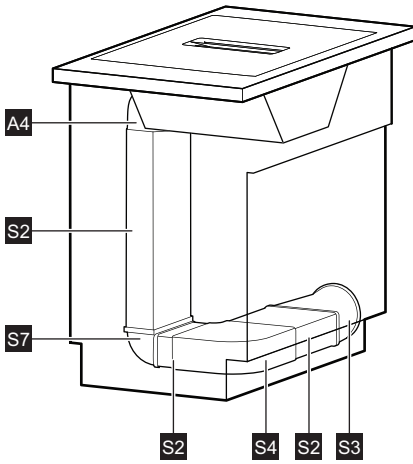
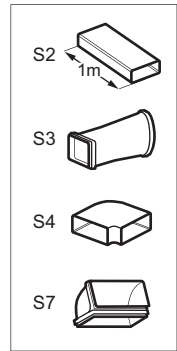

# 2. F.

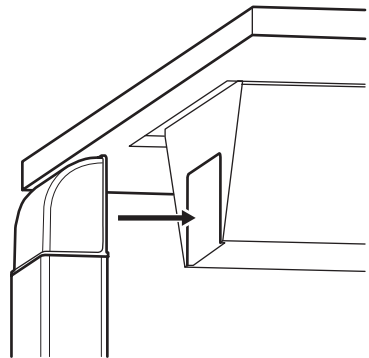
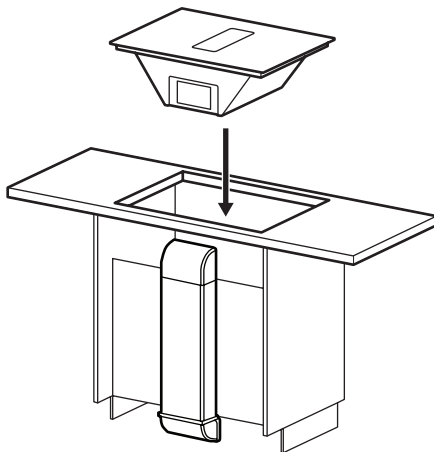



**C D E F**

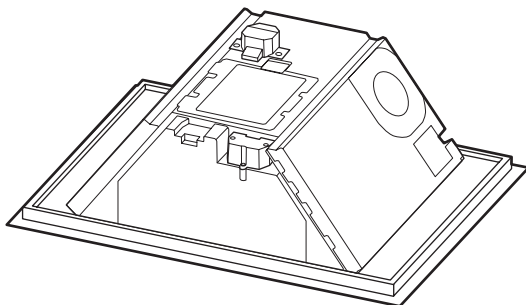

**1**

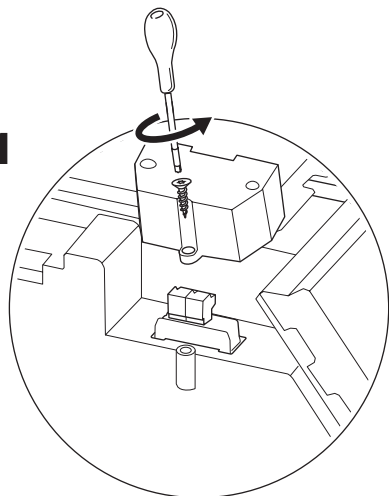

**2**

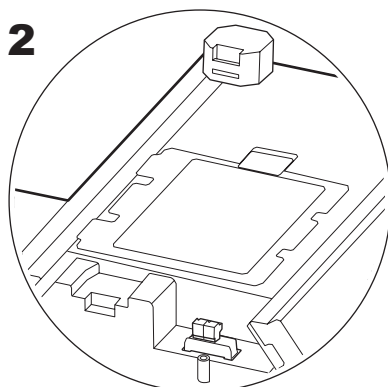

**3**

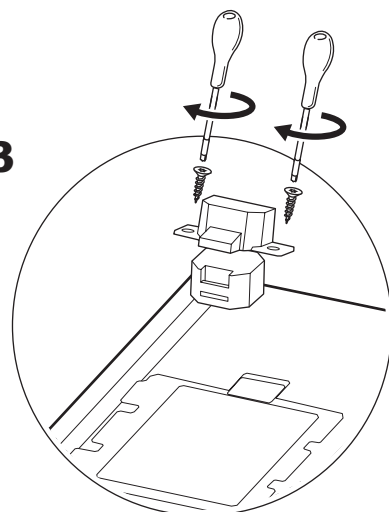

**4**

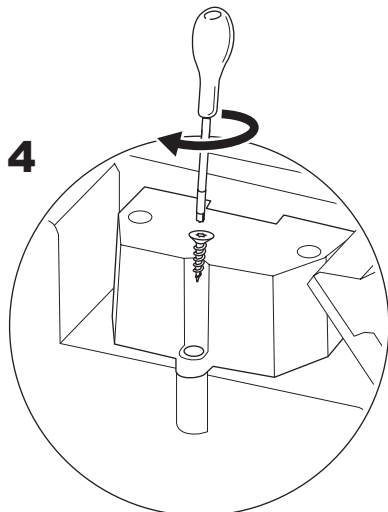









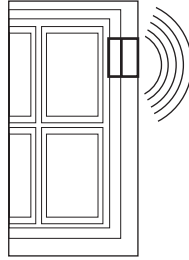





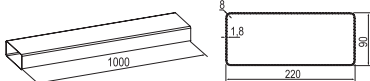

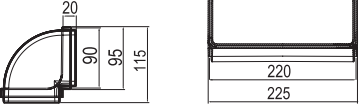
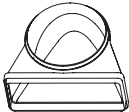
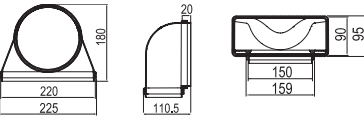

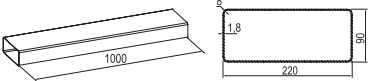
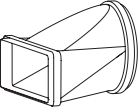
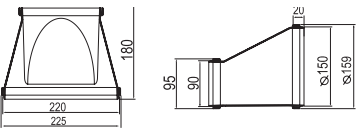
KIT FDS 100

ELEKTROTECHNIK  
SCHABUS **ES**

[www.electrotechnik-schabus.de](http://www.electrotechnik-schabus.de)

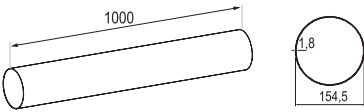

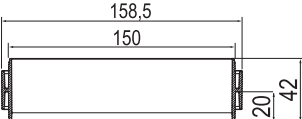
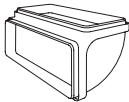
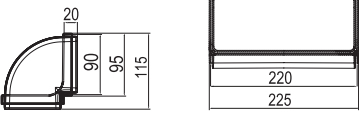
Label	Part description	Picture	Dimensions
A5	M2CKCF06U Rectangular size adapter		
K1	M2CKCF17C - half pipe kit (K1+K2)		
K2	Rectangular pipe + Rectangular vertical 90° curve		
S1	M2CKCF03U Vertical 90° curve from rectangular (220x90mm) to round (ø150mm)		
S2	M2CKCF05U Rectangular pipe, 1 meter (220x90mm)		
S3	M2CKCF02U Straight connection from rectangular (220x90mm) to round (ø150mm)		
S4	M2CKCF04U Rectangular Horizontal 90° curve (220x90mm)		

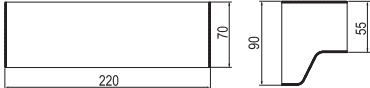
Label	Part description	Picture	Dimensions
S5	M2CKCF07U Round pipe, 1 meter ( $\varnothing$ 150mm)		
S6	M2CKCF08U Female round connection ( $\varnothing$ 150mm)		
S7	M2CKCF09U Rectangular Vertical 90° Curve (220x90mm)		
S8	M2CKCF10U Adhesive PVC tape, 10 m (width 50mm)		
S9	M2CKCF11U Rectangular straight reduction (220mm) from 90 mm to 55 mm		
S10	M2CKCF12U External grid with gravity flaps	